

3M Purification

3M™ HF65S

Water Filter Cartridge



3M™ Water Filtration Products Models HF65S single cartridge water filtration systems help provide consistent high quality water for commercial coffee by reducing the effects of sediment, chlorine taste/ odour and scale at flow rates up to 12.6 lpm. Built-in scale inhibition reduces the ability of calcium and magnesium to precipitate inside equipment as hard scale.

HF65S combines chlorine taste and odour reduction with sediment reduction from higher turbidity water, while reducing the effects of chlorine corrosion and scale for up to 132,489 litres.

Features & Benefits

- Effectively reduces sediment and chlorine taste and odour for better equipment protection and clearer, great tasting coffee.
- NSF Standard 42 and/or FDA CFR-21 compliant materials.
- Built-in scale inhibitor reduces lime scale build-up on evaporator plates as tested 3M Purification.
- Sanitary Quick Change (SQC) encapsulated cartridge design allows for fast and easy cartridge change-outs with a 1/4 turn.
- 3/8" FNPT horizontal inlet and outlet ports allow direct or easily adaptable connections to existing plumbing lines.

Applications

- Coffee

Product Specifications

Model	Part Number	Micron Rating	Reduction Claims	Capacity	Service Flow Rate	Application
HF65S	AK200125552	3	Sediment ¹ , Chlorine, Scale ¹ , Taste & Odour	132,489 litres	12.6 lpm	Higher Turbidity Water

1. Tested and verified by manufacturer's laboratory.



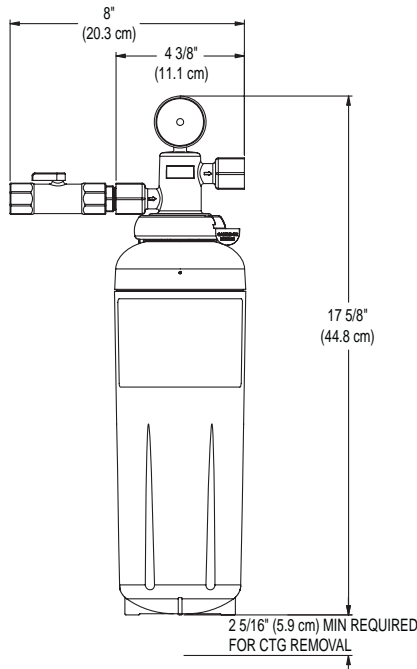

Physical Specifications

- System includes a head assembly with pressure gauge, inlet water shut-off valve assembly, mounting bracket and a single cartridge filter.
- Inlet and outlet plumbing connections are 3/8" FNPT.
- Filter cartridges are o-ring seal type.
- System maximum operating pressure of 125 psi (862 kPa) and operating temperature of 37.8°C.
- Recommended service flow rate is up to 12.6 lpm.
- System materials are NSF Standard 42 and/or FDA CFR-21 compliant.
- Cartridges are sanitary in design, requiring no contact with the filter media during cartridge change-out.
- Filter cartridges require no pre-activation.
- NSF Performance Data Sheet (PDS) is included.
- Shipping weight: 1.9 kg per case.
- Operating weight: 3.4 kg per case.
- Case quantity: 1.

IMPORTANT: Installation Tips

These installation tips are for informational purposes only and are not intended to be used as actual installation instructions.

CAUTION: To reduce the risk associated with property damage due to water leakage:

- Read and follow. Use Instructions before installation and use of this system.
- Installation and use. MUST comply with all state and local plumbing codes.
- Protect from freezing, remove filter cartridge when temperatures are expected to drop below 4.4°C (40°F).
- Do not install on hot water supply lines. The maximum operating water temperature of this filter system is 37.8°C (100°F).
- Do not install if water pressure exceeds 862 kPa (125 psi). As a requirement of the plumbing code, a pressure limiting valve and backflow prevention device must be installed. Contact a plumbing professional if you are uncertain how to check your water pressure.
- Do not install where water hammer conditions may occur. If water hammer conditions exist you must install a water hammer arrester. Contact a plumbing professional if you are uncertain how to check for this condition.
- The disposable filter cartridge MUST be replaced every 12 months, at the rated capacity or if a noticeable reduction in flow rate occurs.

WARNING: Do not use with water that is microbiologically unsafe or of unknown quality without adequate disinfection before or after the system. If system is not used for 2 days or more, flush 5-10 litres of water through before consuming water.

Important Notice

The information described in this literature is accurate to the best of our knowledge. A variety of factors, however, can affect the performance of the Product(s) in a particular application, some of which are uniquely within your knowledge and control. INFORMATION IS SUPPLIED UPON THE CONDITION THAT THE PERSONS RECEIVING THE SAME WILL MAKE THEIR OWN DETERMINATION AS TO ITS SUITABILITY FOR THEIR USE. IN NO EVENT WILL 3M PURIFICATION BE RESPONSIBLE FOR DAMAGES OF ANY NATURE WHATSOEVER RESULTING FROM THE USE OF OR RELIANCE UPON INFORMATION. It is your responsibility to determine if additional testing or information is required and if this product is fit for a particular purpose and suitable in your specific application.

Limitation of Liability

3M Purification Pty Limited will not be liable, to the extent permitted by law, for any loss or damage from the use of the Product(s), whether direct, indirect, special, or consequential, regardless of the legal theory asserted, included warranty, contract, negligence or strict liability.



3M Purification Pty Limited

140 Sunnyholt Road
Blacktown NSW 2148
Australia
Tel: 1300 367 362
Fax: 1800 671 599
www.3mpurification.com.au

3M New Zealand

94 Apollo Drive
Rosedale Auckland 0632
New Zealand
Tel: 0800 362 886
Fax: 0800 362 880
www.3M.com/nz

3M is a trademark of the 3M Company.

Please recycle. Printed in Australia.

© 3M 2014. All rights reserved.

AV011434345